

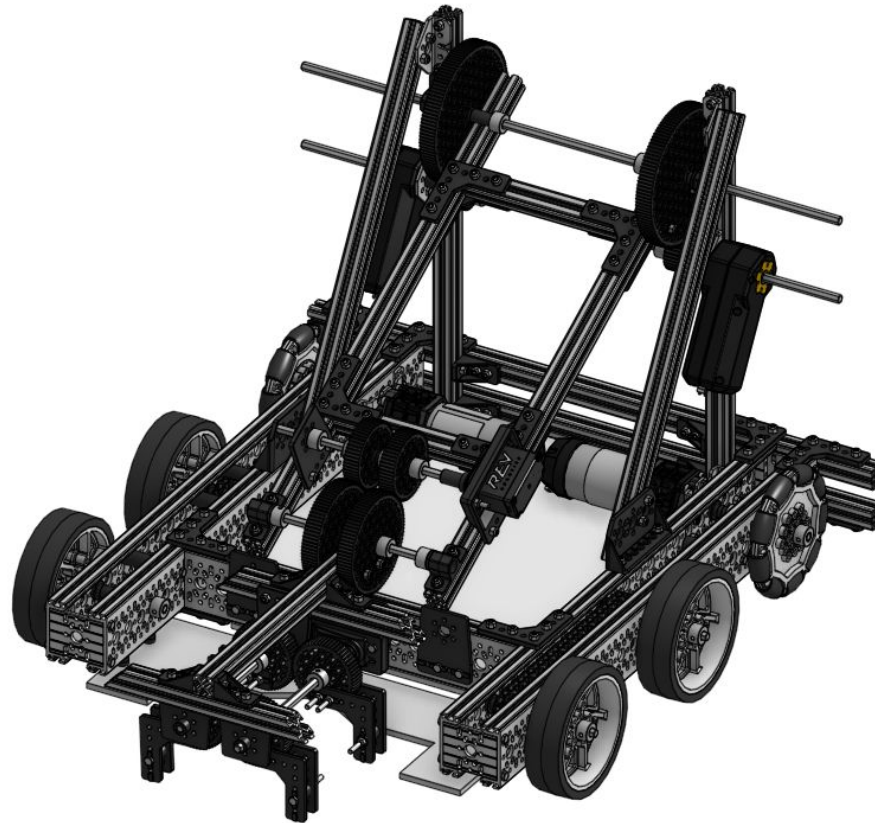

2023-24 REV DUO FTC Starter Bot



PART NUMBER	PRODUCT NAME	QUANTITY	PART NUMBER	PRODUCT NAME	QUANTITY
REV-11-1130	36" PWM Cable	QTY 2	REV-41-1333	125 Tooth Plastic Gear	QTY 2
REV-31-1302	12V Slim Battery	QTY 1	REV-41-1335	60 Tooth Plastic Gear	QTY 6
REV-31-1387	Switch Cable and Bracket	QTY 1	REV-41-1337	90 Tooth Plastic Gear	QTY 2
REV-31-1595	Control Hub	QTY 1	REV-41-1338	10 Tooth #25 Sprocket	QTY 8
REV-31-1596	Driver Hub	QTY 1	REV-41-1348	5mm x 90mm Hex Shaft	QTY 6
REV-39-1865	Etpark Wired Controller for PS4	QTY 1	REV-41-1349	5mm x 135mm Hex Shaft	QTY 4
REV-41-1097	Smart Robot Servo	QTY 2	REV-41-1359	M3 x 8mm Hex Cap Screws	QTY 192
REV-41-1125	M3 x 35mm Hex Cap Screws	QTY 12	REV-41-1360	M3 x 16mm Hex Cap Screws	QTY 16
REV-41-1161	Zip Ties - 160mm - 50 Pack	QTY 1 Pack	REV-41-1361	M3 Nyloc Nuts	QTY 212
REV-41-1163	Surgical Tubing - 3mm	QTY 1	REV-41-1362	5mm x 400mm Hex Shaft	QTY 2
REV-41-1190	90mm Omni Wheel	QTY 2	REV-41-1365	#25 Roller Chain - 10 ft	QTY 1
REV-41-1267	90mm Grip Wheel	QTY 4	REV-41-1373	Hook and Loop Fastener - 13.5mm x 2mm	QTY 1
REV-41-1300	Core Hex Motor	QTY 2	REV-41-1430	15mm Extrusion - 150mm - 45° Ends	QTY 2
REV-41-1303	15mm Plastic Motion Bracket	QTY 4	REV-41-1431	15mm Extrusion - 225mm - 90° Ends	QTY 1
REV-41-1305	15mm Plastic 90 Degree Bracket	QTY 26	REV-41-1432	15mm Extrusion - 420mm - 90° Ends	QTY 8
REV-41-1315	15mm Gearbox Motion Bracket	QTY 2	REV-41-1433	15mm Metal Bent Core Hex Motor Bracket V2	QTY 4
REV-41-1317	15mm Bearing Pillow Block	QTY 4	REV-41-1492	M3 Standoff - 40mm	QTY 8
REV-41-1319	15mm Plastic Servo Bracket	QTY 2	REV-41-1568	15mm Extrusion - 120mm - 90° Ends	QTY 2
REV-41-1321	15mm Plastic Lap Corner Bracket	QTY 8	REV-41-1600	UltraPlanetary Gearbox Kit & HD Hex Motor	QTY 2
REV-41-1323	15mm Spacer	QTY 10	REV-41-1621	UltraPlanetary Outside Mounting Bracket	QTY 2
REV-41-1324	3mm Spacer	QTY 24	REV-41-1687	U Channel Endcap	QTY 4
REV-41-1326	Through Bore Bearing - Short	QTY 16	REV-41-1702	Tensioning Bushing - 39mm	QTY 8
REV-41-1327	Shaft Collars	QTY 29	REV-41-1762	45mm x 15mm C Channel - 408mm	QTY 4
REV-41-1328	Servo Shaft Adapter	QTY 2	REV-41-1767	45mm x 15mm C Channel - 248mm	QTY 1
REV-41-1329	Through Bore Bearing - Long	QTY 12	REV-41-1839	450mm x 300mm x 4mm Corrugated Plastic Sheet	QTY 2
REV-41-1332	30 Tooth Plastic Gear	QTY 2	REV-41-1907	M3 X 8MM T-Slot Screw	QTY 40

Tower Assembly

PART NUMBER	PRODUCT NAME	QTY
REV-41-1300	Core Hex Motor	2
REV-41-1315	15mm Gearbox Motion Bracket	2
REV-41-1317	15mm Bearing Pillow Block	2
REV-41-1323	15mm Spacer	2
REV-41-1324	3mm Spacer	4
REV-41-1327	Shaft Collars	2
REV-41-1332	30 Tooth Plastic Gear	2
REV-41-1359	M3 x 8mm Hex Cap Screw	4
REV-41-1361	M3 Nyloc Nuts	38
REV-41-1362	5mm x 400mm Hex Shaft	1
REV-41-1432	15mm Extrusion - 420mm - 90° Ends	4
REV-41-1433	15mm Metal Bent Core Hex Motor Bracket V2	4
REV-41-1907	M3 X 8mm T-Slot Screw	16



Cut List

Extrusion can be cut with either a hand-held hacksaw or with a band saw. Be sure that pieces are properly secured, ideally with clamps, before cutting. Using a circular or chop saw is NOT recommended.

420mm Extrusion

Length	QTY.	ASSEMBLY
300mm	4	TOWER
380mm	2	ARM

1



Get:

- 1 - 15mm Metal Bent Core Hex Motor Bracket V2
- 6 - M3 X 8mm T-Slot Screws
- 6 - M3 Nyloc Nuts
- 1 - 15mm Plastic Lap Corner Bracket
- 1 - 300mm cut Extrusion

Attach the Brackets to the 300mm cut extrusion as shown using T-Slot Screws and Nyloc Nuts

2



Get:

- 1 - 15mm Metal Bent Core Hex Motor Bracket V2
- 2 - M3 X 8mm T-Slot Screw
- 2 - M3 Nyloc Nuts
- 1 - Core Hex Motor
- 2 - M3 x 8mm Hex Cap Screws

Attach the Bracket extrusion as shown using T-Slot Screws and Nyloc Nuts. Then attach the Core Hex Motor using Hex Cap Screws

3



Get:

- 1 - 300mm cut Extrusion

Attach the 300mm cut extrusion with the preloaded 2 M3 X 8mm T-Slot Screw and M3 Nyloc Nuts

4



Get:

- 1 - 15mm Gearbox Motion Bracket
- 4 - M3 X 8mm T-Slot Screw
- 4 - M3 Nyloc Nuts

Attach the Gearbox Motion Bracket to the 300mm cut extrusion with T-Slot Screws and M3 Nyloc Nuts then preload T-Slot Screws and M3 Nyloc Nuts as shown.

5



Get:

- 1 - 15mm Metal Bent Core Hex Motor Bracket V2
- 6 - M3 X 8mm T-Slot Screws
- 6 - M3 Nyloc Nuts
- 1 - 15mm Plastic Lap Corner Bracket
- 1 -300mm cut Extrusion

Attach the Brackets to the 300mm cut extrusion as shown using T-Slot Screws Screws and Nyloc Nuts

6



Get:

- 1 - 15mm Metal Bent Core Hex Motor Bracket V2
- 2 - M3 X 8mm T-Slot Screw
- 2 - M3 Nyloc Nuts
- 1 - Core Hex Motor
- 2 - M3 x 8mm Hex Cap Screws

Attach the Bracket extrusion as shown using T-Slot Screws Screws and Nyloc Nuts. Then attach the Core Hex Motor using Hex Cap Screws

7



Get:

- 1 - 300mm cut Extrusion

Attach the 300mm cut extrusion with the preloaded 2 M3 X 8mm T-Slot Screw and M3 Nyloc Nuts

8

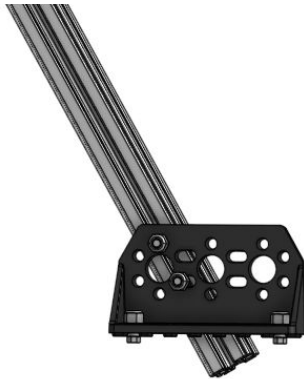

Get:

- 1 - 15mm Gearbox Motion Bracket
- 4 - M3 X 8mm T-Slot Screw
- 4 - M3 Nyloc Nuts

Attach the Gearbox Motion Bracket to the 300mm cut extrusion with T-Slot Screws and M3 Nyloc Nuts then preload T-Slot Screws and M3 Nyloc Nuts as shown.

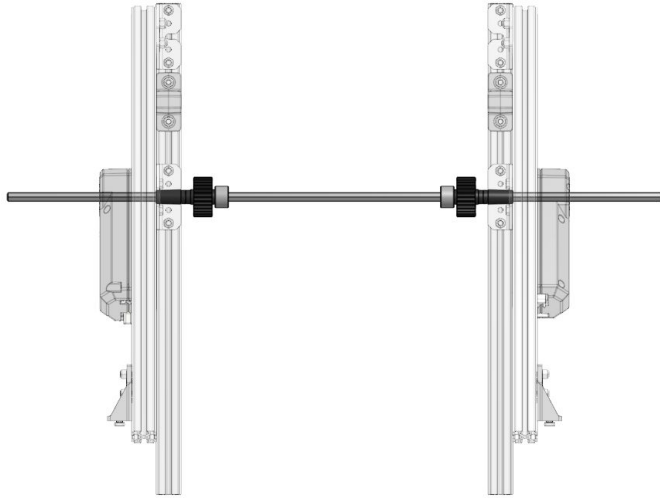
**Get:**

- 2 - Shaft Collars
- 2 - 30 Tooth Plastic Gears
- 4 - 3mm Spacers
- 2 - 15mm Spacers
- 1 - 5mm x 400mm Hex Shaft

Slide the above onto the the Hex Shaft. Insert the shaft through both Core Hex Motors.

Note: You may need to adjust the shaft collars to align the gears later.

Intentionally Left Blank

Arm Assembly

PART NUMBER	PRODUCT NAME	QTY
REV-41-1097	Smart Robot Servo	1
REV-41-1303	15mm Plastic Motion Bracket	1
REV-41-1305	15mm Plastic 90 Degree Bracket	8
REV-41-1317	15mm Bearing Pillow Block	2
REV-41-1319	15mm Plastic Servo Bracket	1
REV-41-1323	15mm Spacer	2
REV-41-1324	3mm Spacer	3
REV-41-1327	Shaft Collars	6
REV-41-1328	Servo Shaft Adapter	1
REV-41-1329	Through Bore Bearing - Long	3
REV-41-1333	125 Tooth Plastic Gear	2
REV-41-1335	60 Tooth Plastic Gear	2
REV-41-1349	5mm x 135mm Hex Shaft	1
REV-41-1359	M3 x 8mm Hex Cap Screws	48
REV-41-1360	M3 x 16mm Hex Cap Screws	8
REV-41-1361	M3 Nyloc Nuts	56
REV-41-1362	5mm x 400mm Hex Shaft	1
REV-41-1432	15mm Extrusion - 420mm - 90° Ends	2
REV-41-1568	15mm Extrusion - 120mm - 90° Ends	2



1



Get:

- 4 - 15mm Plastic 90 Degree Brackets
- 22 - M3 X 8mm Hex Cap Screws
- 22 - M3 Nyloc Nuts
- 1 - 15mm Bearing Pillow Block
- 1 - 380mm cut Extrusion

Fully preload four Plastic 90 Degree Brackets with Hex Cap Screws and Nyloc Nuts. Then fasten the brackets to the top and bottom the extrusion as shown. Then slide a Bearing Pillow Block and fasten it with two Hex Cap Screws and Nyloc Nuts.

2



Get:

- 4 - 15mm Plastic 90 Degree Brackets
- 22 - M3 X 8mm Hex Cap Screws
- 22 - M3 Nyloc Nuts
- 1 - 15mm Bearing Pillow Block
- 1 - 380mm cut Extrusion

Fully preload four Plastic 90 Degree Brackets with Hex Cap Screws and Nyloc Nuts. Then fasten the brackets to the top and bottom the extrusion as shown. Then slide a Bearing Pillow Block and fasten it with two Hex Cap Screws and Nyloc Nuts.

3



Get:

- 2 - 15mm Extrusion - 120mm - 90° Ends

Slide the 120mm extrusion into the 90 Degree Brackets connecting the 380mm cut Extrusion with brackets.

4

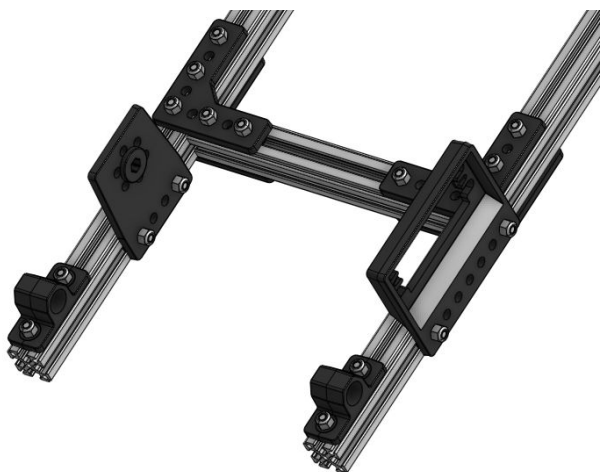

Get:

- 1 - 15mm Plastic Servo Bracket
- 1 - 15mm Plastic Motion Bracket
- 4 - M3 X 8mm Hex Cap Screws
- 4 - M3 Nyloc Nuts

Attach the Brackets to the extrusion as shown using Hex Cap Screws and Nyloc Nuts.

Note: Do not preload the Plastic Servo Bracket. Slide the Hex Cap Screws into the extrusion before attaching the Plastic Servo Bracket.

5



Get:

- 1 - Smart Robot Servo
- 2 - M3 x 16mm Hex Cap Screws
- 2 - M3 Nyloc Nuts

Attach a Smart Robot Servo to the Plastic Servo Bracket using 16mm Hex Cap Screws and Nyloc Nuts.

6

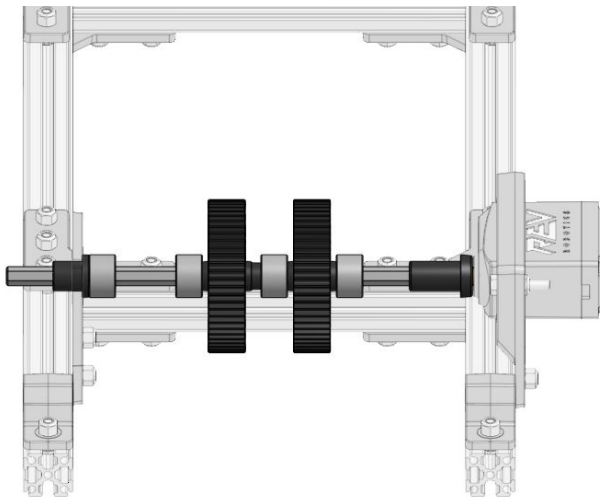

Get:

- 1 - Through Bore Bearing - Long
- 2 - 60 Tooth Plastic Gears
- 4 - Shaft Collars
- 1 - 3mm Spacer
- 1 - Servo Shaft Adapter
- 1 - 5mm x 135mm Hex Shaft

Slide the above onto the the Hex Shaft as shown. Insert the shaft through Plastic Motion Bracket and attached to the Smart Robot Servo.

Note: You may need to adjust the shaft collars to align the gears later.

7

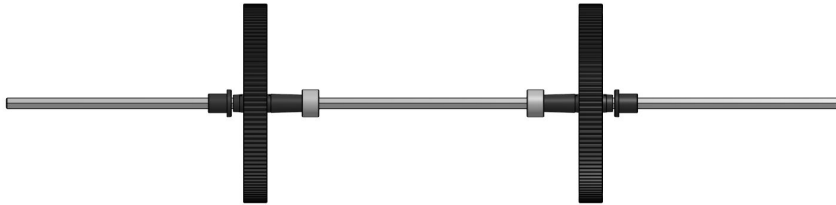

Get:

- 2 - Through Bore Bearing - Long
- 2 - 125 Tooth Plastic Gears
- 2 - 15mm Spacers
- 2 - Shaft Collars
- 2 - 3mm Spacer
- 1 - 5mm x 400mm Hex Shaft

Slide the above onto the the Hex Shaft as shown. Insert the shaft through Plastic Motion Bracket and attached to the Smart Robot Servo.

Note: You may need to adjust the shaft collars to align the gears later.

Intentionally Left Blank

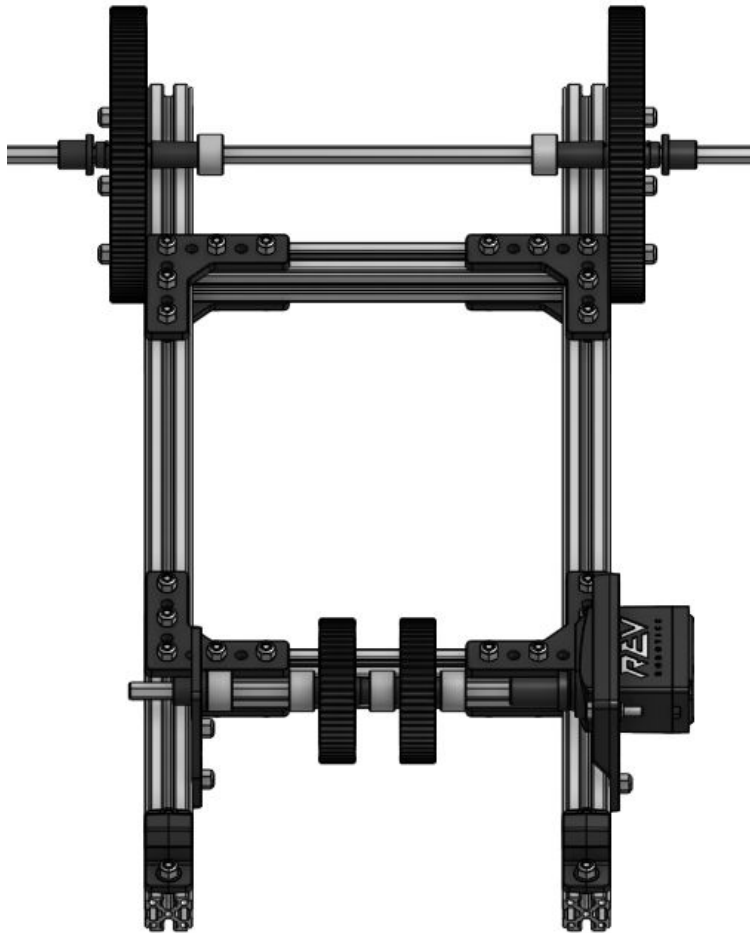
**Get:**

- 6 - M3 X 8mm Hex Cap Screws
- 6 - M3 Nyloc Nuts

Attach the Hex Shaft to the Arm Assembly as shown using Hex Cap Screws and Nyloc Nuts.

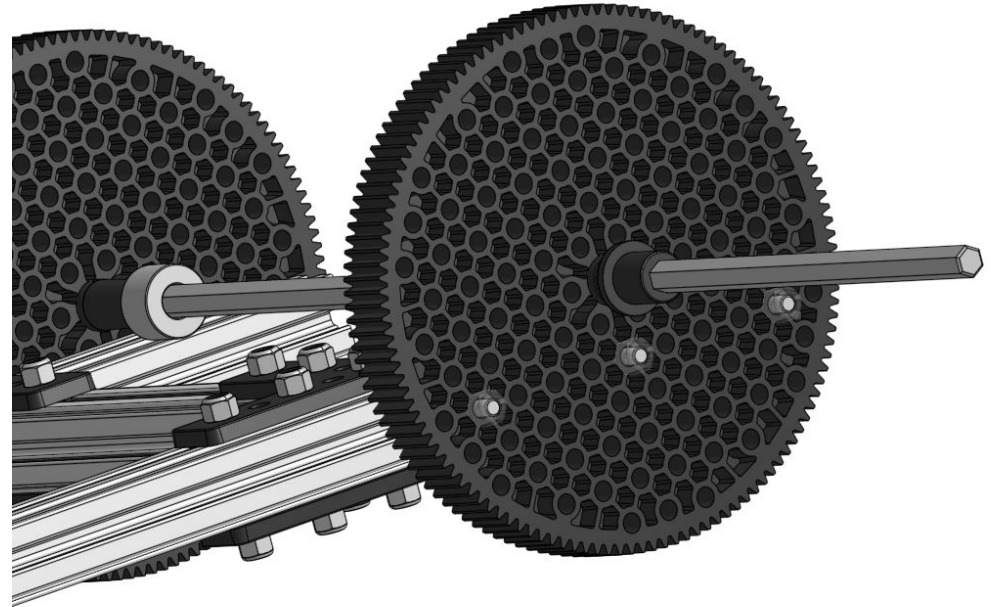

Gripper Assembly

PART NUMBER	PRODUCT NAME	QTY
REV-41-1097	Smart Robot Servo	1
REV-41-1125	M3 x 35mm Hex Cap Screws	12
REV-41-1303	15mm Plastic Motion Bracket	3
REV-41-1305	15mm Plastic 90 Degree Bracket	8
REV-41-1319	15mm Plastic Servo Bracket	1
REV-41-1321	15mm Plastic Lap Corner Bracket	4
REV-41-1323	15mm Spacer	4
REV-41-1324	3mm Spacer	1
REV-41-1326	Through Bore Bearing - Short	2
REV-41-1327	Shaft Collars	9
REV-41-1328	Servo Shaft Adapter	1
REV-41-1329	Through Bore Bearing - Long	5
REV-41-1335	60 Tooth Plastic Gear	4
REV-41-1337	90 Tooth Plastic Gear	2
REV-41-1349	5mm x 135mm Hex Shaft	3
REV-41-1359	M3 x 8mm Hex Cap Screws	20
REV-41-1360	M3 x 16mm Hex Cap Screws	8
REV-41-1361	M3 Nyloc Nuts	40
REV-41-1430	15mm Extrusion - 150mm - 45° Ends	2
REV-41-1431	15mm Extrusion - 225mm - 90° Ends	1
REV-41-1163	Surgical Tubing - 3mm	1

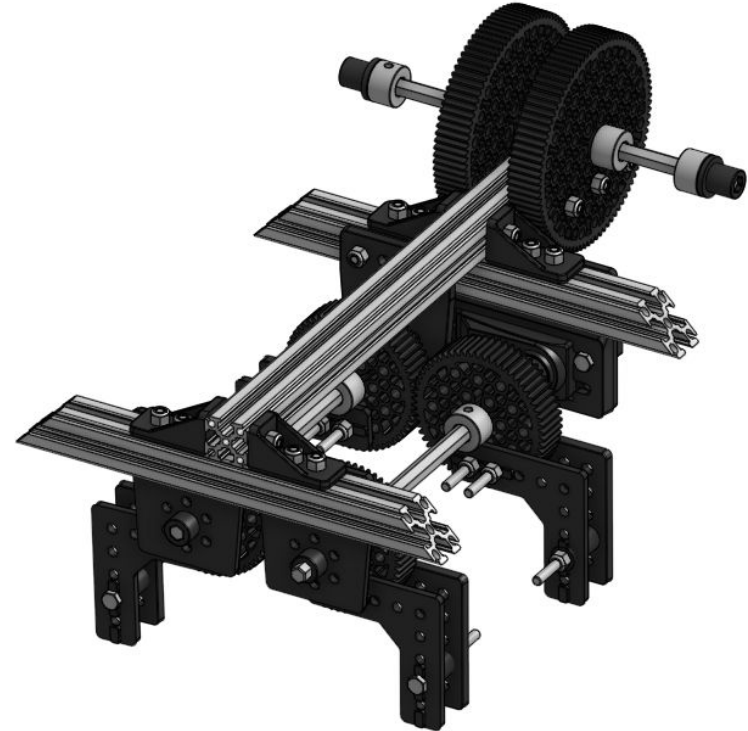

1

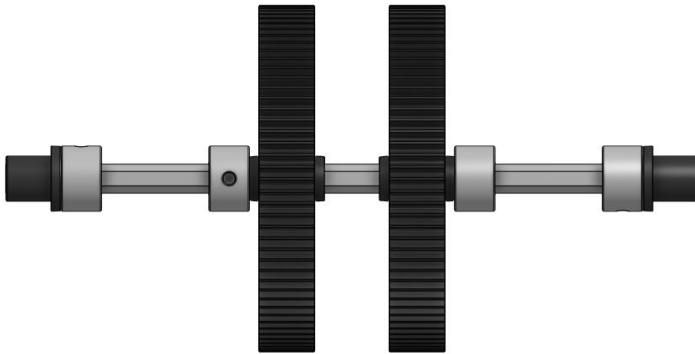

Get:

- 2 - Through Bore Bearing - Long
- 2 - 90 Tooth Plastic Gears
- 4 - Shaft Collars
- 1 - 5mm x 135mm Hex Shaft

Slide the above onto the the Hex Shaft as shown.

2

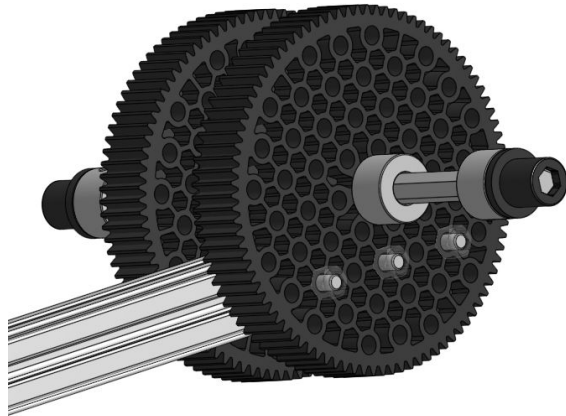

Get:

- 1 - 15mm Extrusion - 225mm - 90° Ends
- 6 - M3 X 8mm Hex Cap Screws
- 6 - M3 Nyloc Nuts

Fasten the Shaft to the Extrusion using Hex Cap Screws and Nyloc Nuts.

3



Get:

- 4 - 15mm Plastic Lap Corner Bracket
- 4 - M3 X 8mm Hex Cap Screws
- 4 - M3 Nyloc Nuts

Fasten the Corner Brackets to the Extrusion using Hex Cap Screws and Nyloc Nuts.

4



Get:

- 2 - 15mm Extrusion - 150mm - 45° Ends
- 8 - M3 X 8mm Hex Cap Screws
- 8 - M3 Nyloc Nuts

Fasten the Extrusion to the Corner Brackets using Hex Cap Screws and Nyloc Nuts.

5

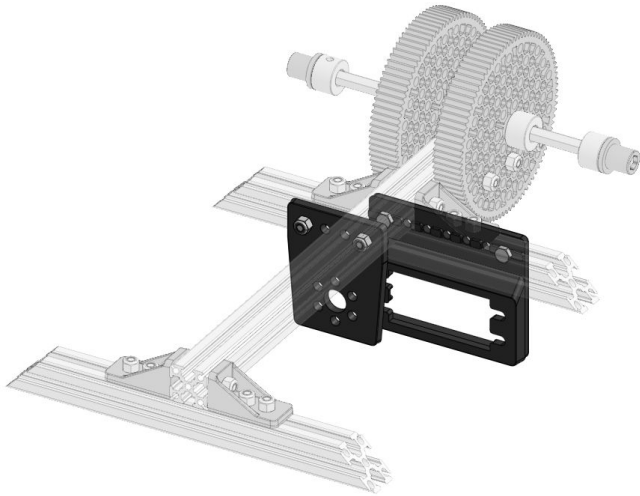

Get:

- 1 - 15mm Plastic Motion Bracket
- 1 - Servo Bracket
- 4 - M3 X 8mm Hex Cap Screws
- 4 - M3 Nyloc Nuts

Fasten the Brackets to the Extrusion using Hex Cap Screws and Nyloc Nuts.

6

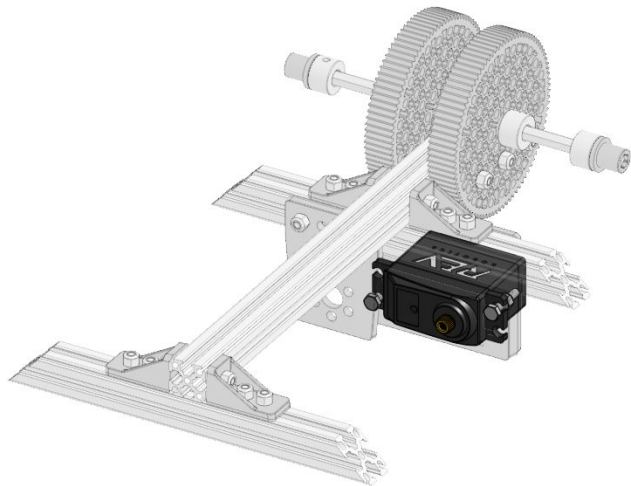

Get:

- 1 - Smart Robot Servo
- 2 - M3 X 16mm Hex Cap Screws
- 2 - M3 Nyloc Nuts

Fasten the Smart Robot Servo to the bracket using Hex Cap Screws and Nyloc Nuts.

Get:

- 4 - 60 Tooth Plastic Gear
- 8 - 15mm Plastic 90 Degree Bracket
- 4 - 15mm Spacer
- 12 - M3 X 35mm Hex Cap Screws
- 12 - M3 Nyloc Nuts

Fasten two Brackets and a 15mm Spacer to a Gear using Hex Cap Screws and Nyloc Nuts as shown. Do this four times to have four total gears, and two matching pairs. Please Note: The 90 Degree Brackets will need to be slightly flexed to accommodate the 15mm Spacers.

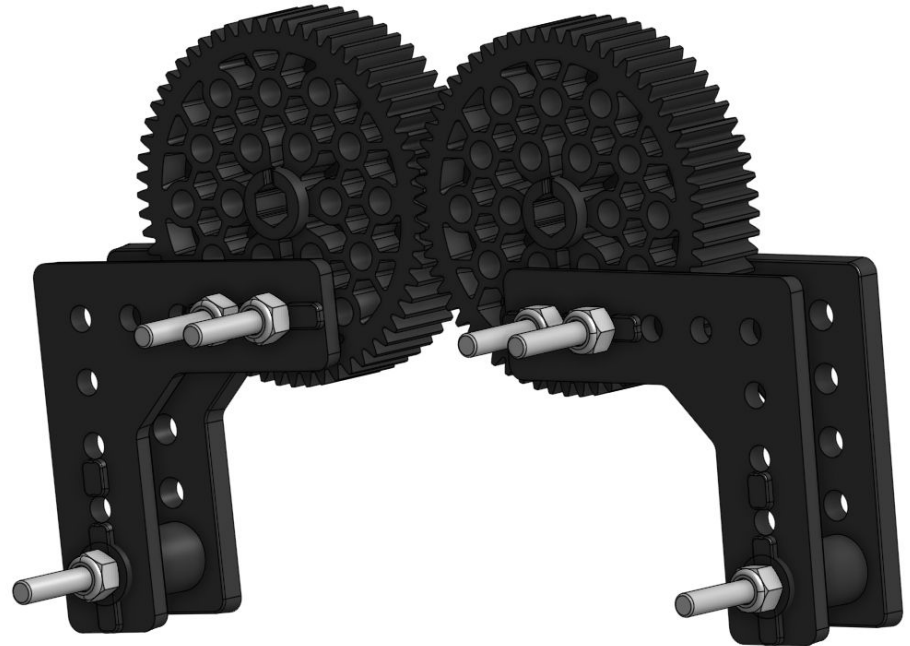
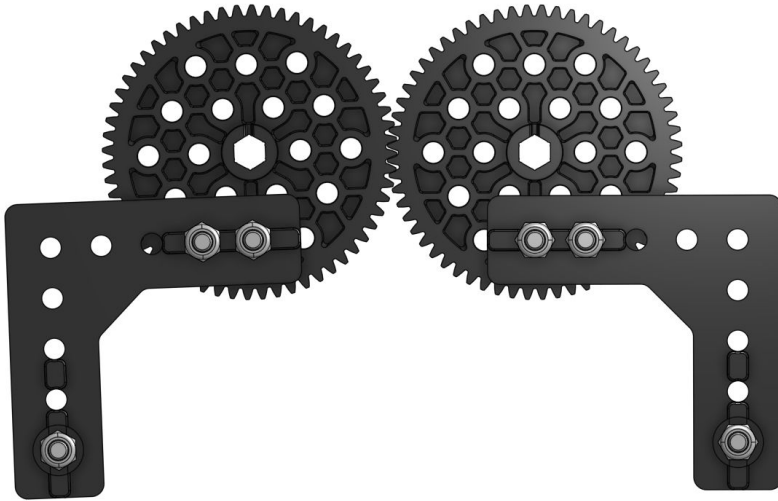

8

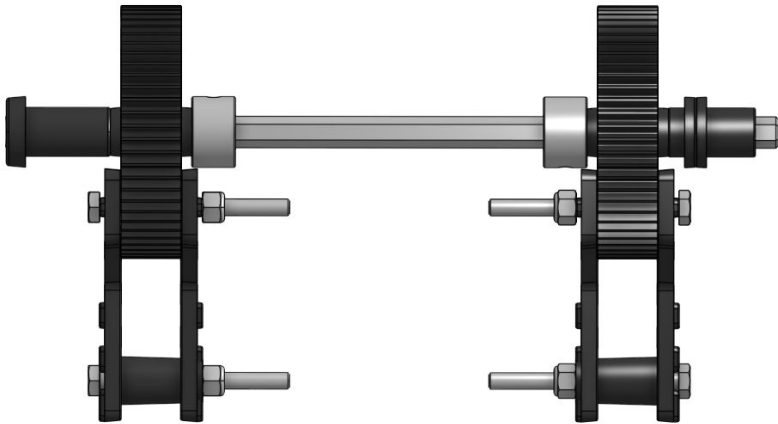

Get:

- 1 - Through Bore Bearing - Long
- 1 - Through Bore Bearing - Short
- 2 - 60 Tooth Plastic Gears with 90 Degree Brackets
- 2 - Shaft Collars
- 1 - Servo Adapter
- 1 - 5mm x 135mm Hex Shaft

Slide the above onto the shaft as shown to make the Right Gripper Shaft.

Note: You may need to adjust the shaft collars to align the gears later.

9

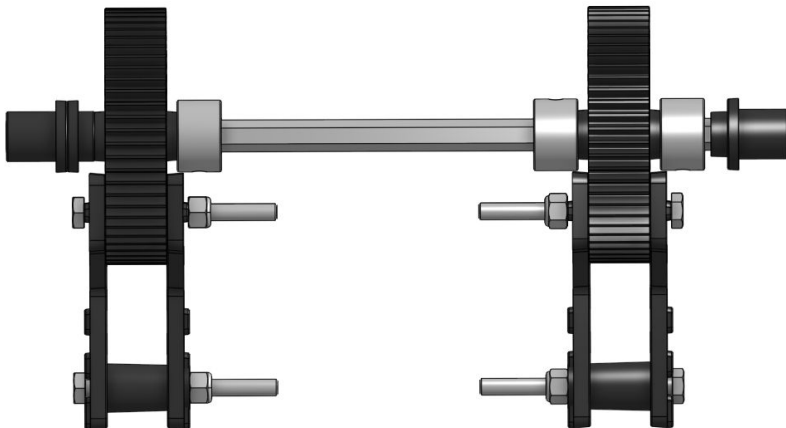

Get:

- 2 - Through Bore Bearing - Long
- 1 - Through Bore Bearing - Short
- 2 - 60 Tooth Plastic Gears with 90 Degree Brackets
- 3 - Shaft Collars
- 1 - 5mm x 135mm Hex Shaft

Slide the above onto the shaft as shown to make the Left Gripper Shaft.

Note: You may need to adjust the shaft collars to align the gears later.

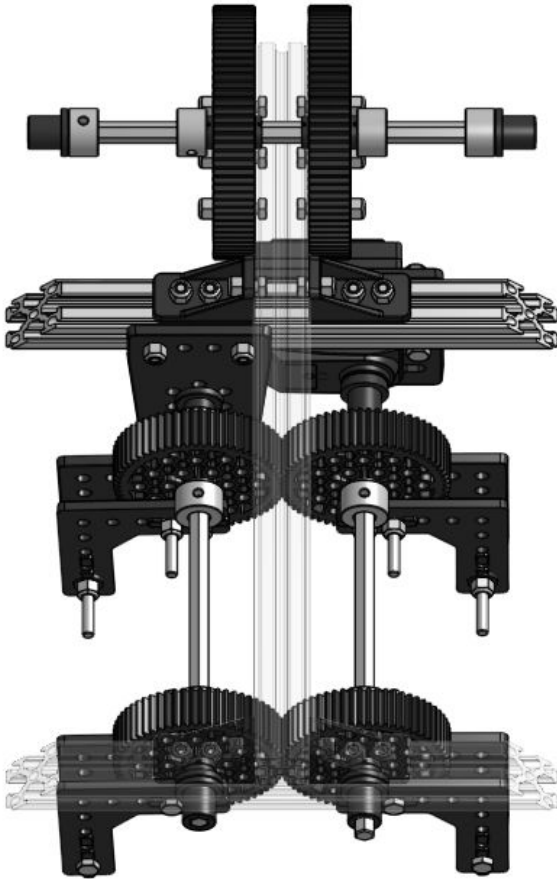
**Get:**

- 2 - 15mm Plastic Motion Bracket
- 4 - M3 X 8mm Hex Cap Screws
- 4 - M3 Nyloc Nuts
- Right Gripper Shaft
- Left Gripper Shaft

Insert the Right Gripper shaft onto the Servo. Insert the Left Gripper shaft into the Motion Bracket. Slide two Motion Brackets onto the extrusion and insert the Gripper shafts into the brackets. Fasten the brackets with Hex Cap Screws and Nyloc Nuts.

Note: This is a good place to align gears, adjust bearings, and tightened shaft collars.

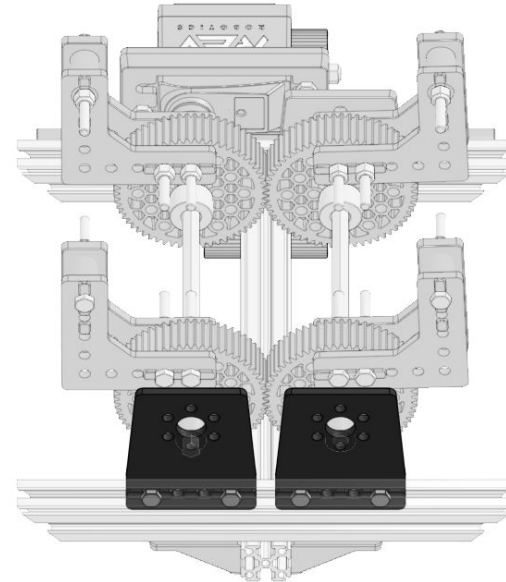

Assembly

PART NUMBER	PRODUCT NAME	QTY
	Channel Drivetrain	1
	Arm Assembly	1
	Gripper Assembly	1
	Tower Assembly	1
REV-41-1321	15mm Plastic Lap Corner Brackets	4
REV-41-1359	M3 x 8mm Hex Cap Screw	4
REV-41-1361	M3 Nyloc Nuts	12
REV-41-1907	M3 X 8mm T-Slot Screw	8



1



Get:

- Channel Drivetrain

Loosen the 12 screws securing the C Channel on the Drivetrain, slide the C Channel away from the motors stopping against the Hex Cap Screws securing the Standoffs and Tension Bushings.

2

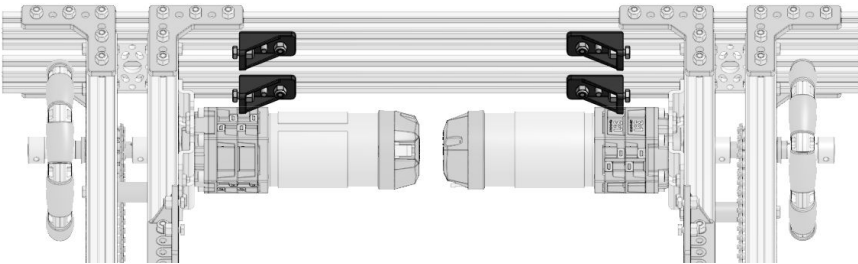

Get:

- 4 - 15mm Plastic Lap Corner Brackets
- 4 - M3 X 8mm Hex Cap Screws
- 8 - M3 X 8mm T-Slot Screw
- 8 - M3 Nyloc Nuts

Preload four Corner Brackets with one Hex Cap Screw and a Nyloc Nut on the short side of the bracket and two T-Slot Screws in the long side. Start a Nyloc Nut to the outside T-Slot Screw, leaving the middle screw open to allow access to the Hex Cap Screw. Fasten the Brackets onto the Channel Drivetrain as shown.

Note: You may need to adjust the brackets later.

3

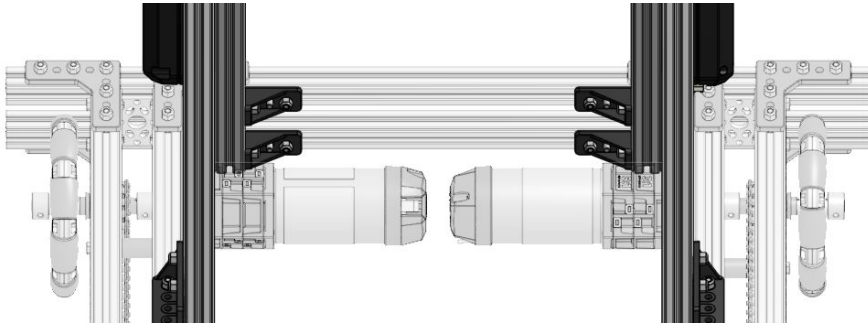

Get:

- Tower Assembly
- 4 - M3 Nyloc Nuts

Slide the Tower Assembly onto the Hex Cap Screws in the Corner Brackets as shown. Adjust the Brackets as necessary to center the tower. Tighten the Hex Cap Screws and then add the Nyloc Nuts to the middle T-Slot Screws and tighten all the nuts.

4

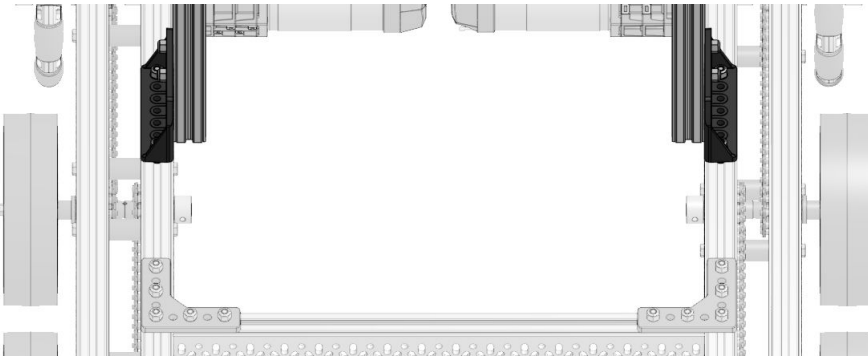

Fasten the preloaded Gearbox Motion Bracket to the Channel Drivetrain.

5

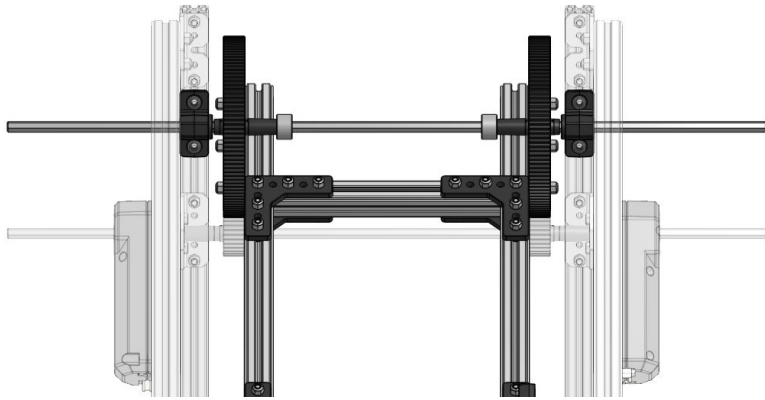

Attach the Arm Assembly to the Tower Assembly by loosening the Metal Bent Core Hex Motor Brackets, removing both the Bearing Pillow Blocks from the Tower Assembly and sliding them onto the Arm Assembly shaft. Then Slide the Bearing Pillow Blocks back into place connecting the gears on the Arm Assembly to the Tower Assembly. Then reattach the Metal Bent Core Hex Motor Brackets.

Note: This is a good place to align gears, adjust bearings, and tightened shaft collars.

6

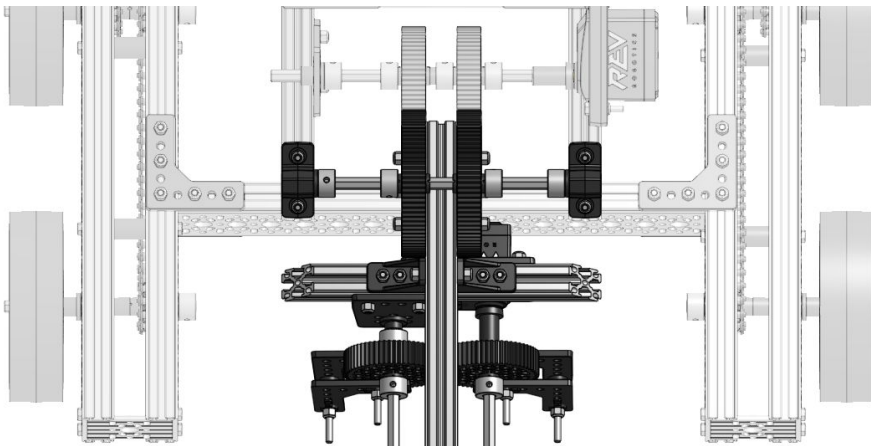

Attach the Gripper Assembly to the Arm Assembly by removing both the Bearing Pillow Blocks from the Arm Assembly and sliding them onto the Gripper Assembly shaft. Then slide the Bearing Pillow Blocks back into place connecting the gears on the Gripper Assembly to the Arm Assembly.

Note: This is a good place to align gears, adjust bearings, and tightened shaft collars.

Electronics and Plastics Assembly

PART NUMBER	PRODUCT NAME	QTY
REV-41-1839	400mm x 350mm x 4mm Cor Plastic Sheet	2
REV-41-1303	15mm Plastic Motion Bracket	2
REV-41-1359	M3 x 8mm Hex Cap Screws	12
REV-41-1361	M3 Nyloc Nuts	18
REV-41-1161	Zip Ties - 160mm - 50 Pack	13
REV-41-1163	Surgical Tubing - 3mm	1
REV-41-1373	Hook and Loop Fastener - 13.5mm x 2mm	1
REV-41-1327	Shaft Collars	6
REV-41-1360	M3 x 16mm Hex Cap Screws	4
REV-41-1324	3mm Spacer	12
REV-31-1387	Switch Cable and Bracket	1
REV-41-1907	M3 X 8mm T-Slot Screw	2

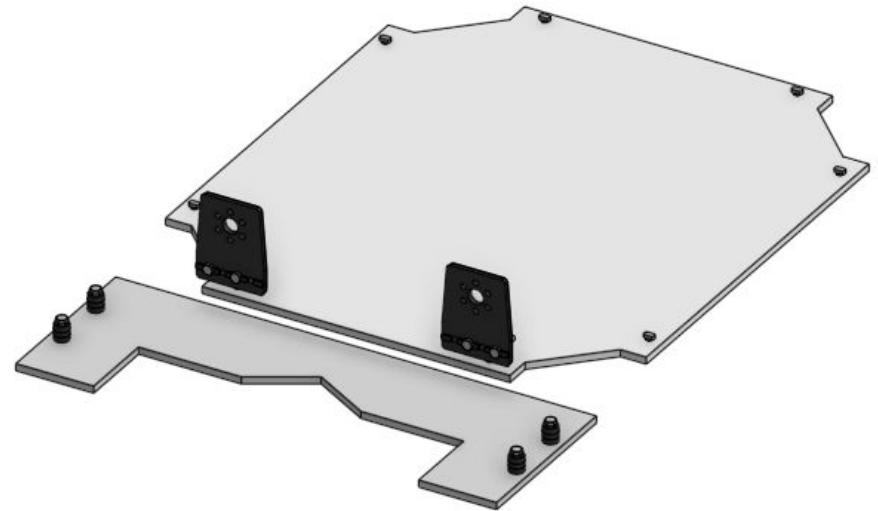

Belly Pan and Intake Guide

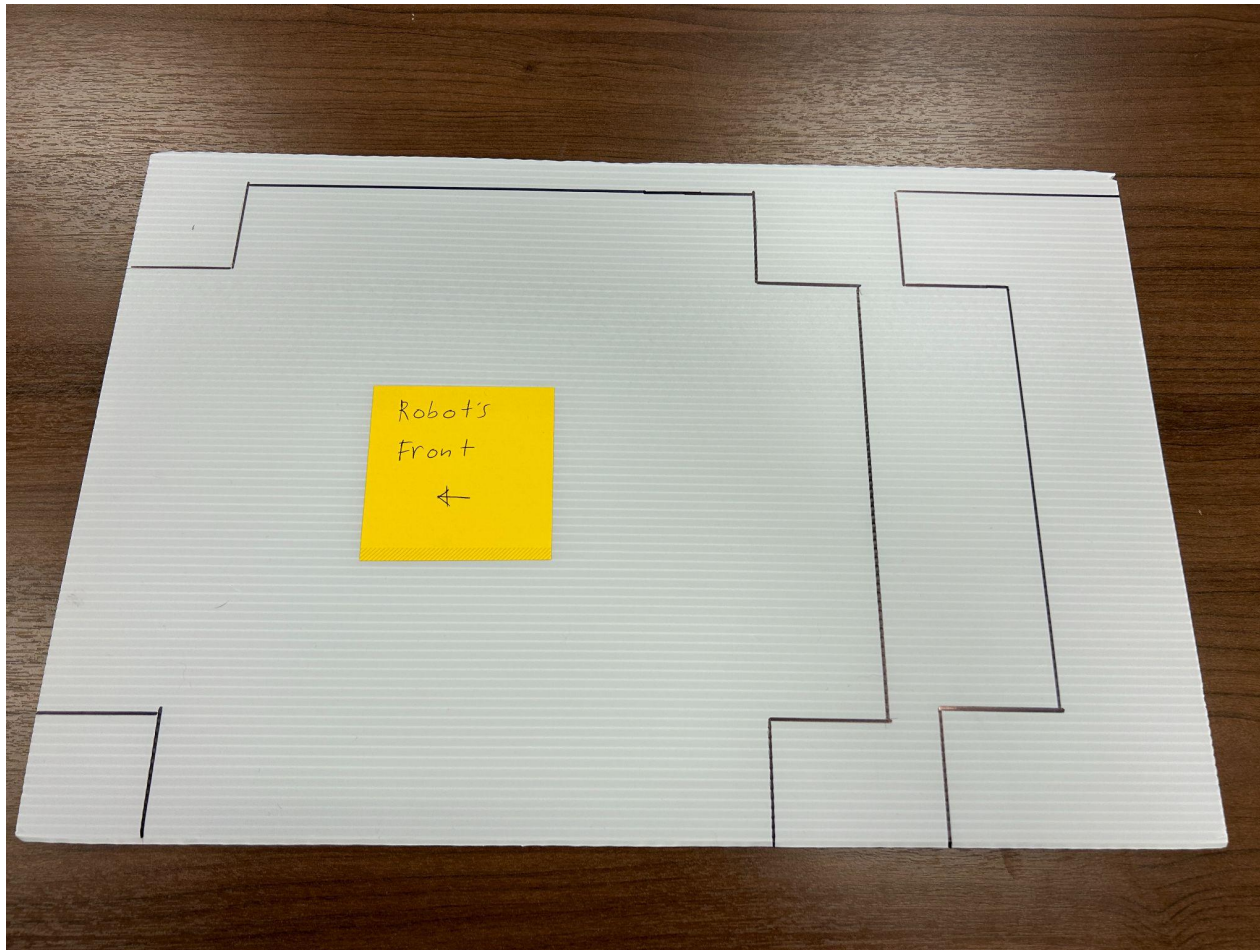

Belly Pan

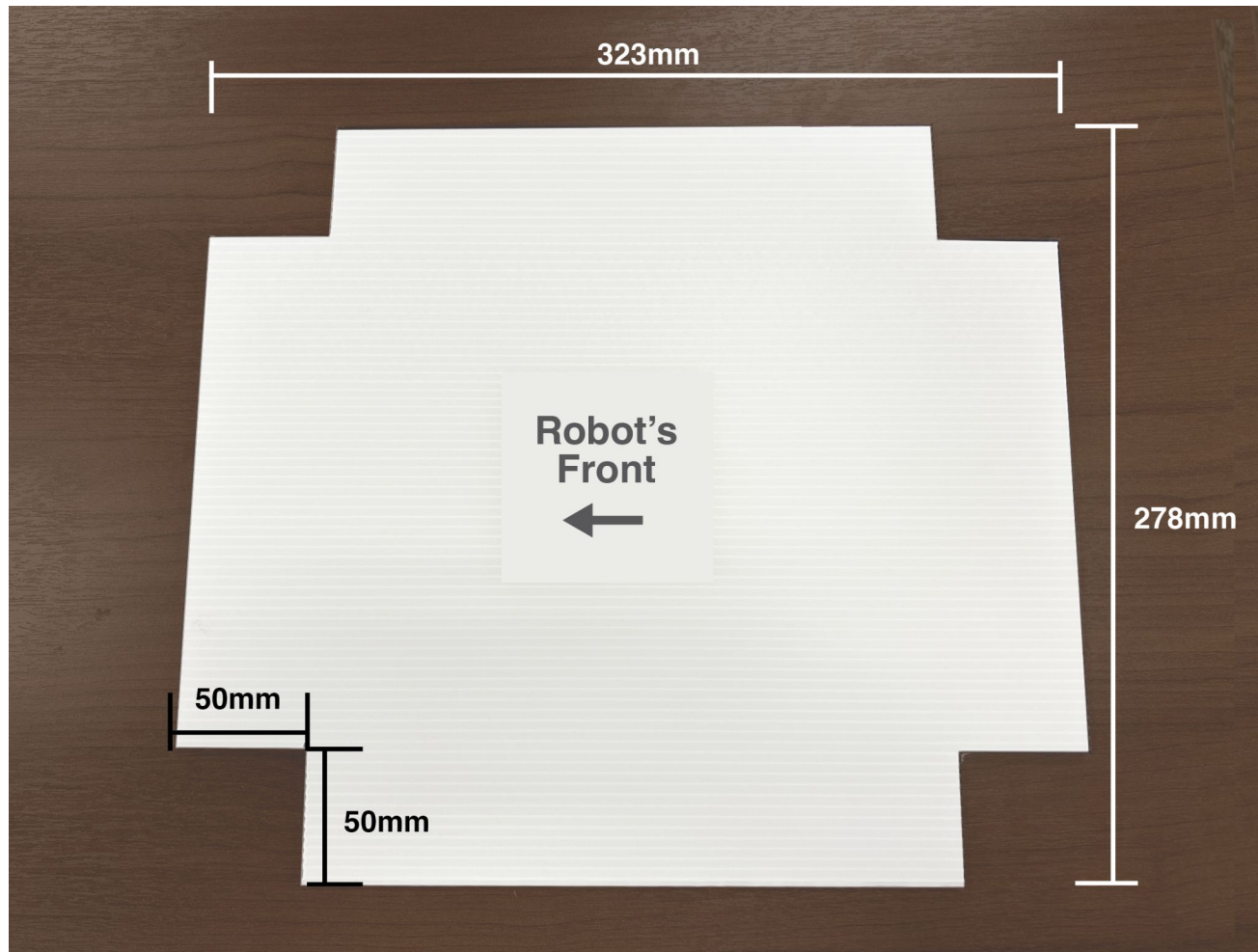

1

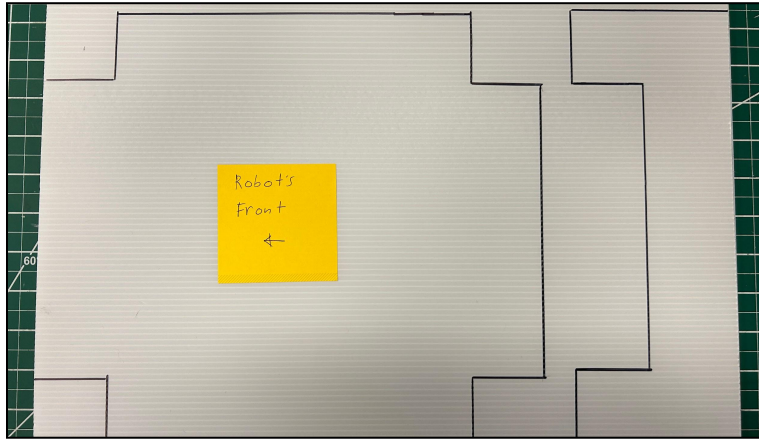

Get:

- 1 x Corrugated Plastic Sheet

Take the corrugated plastic sheet and cut the vertical right 278mm length of your Belly Pan.

2

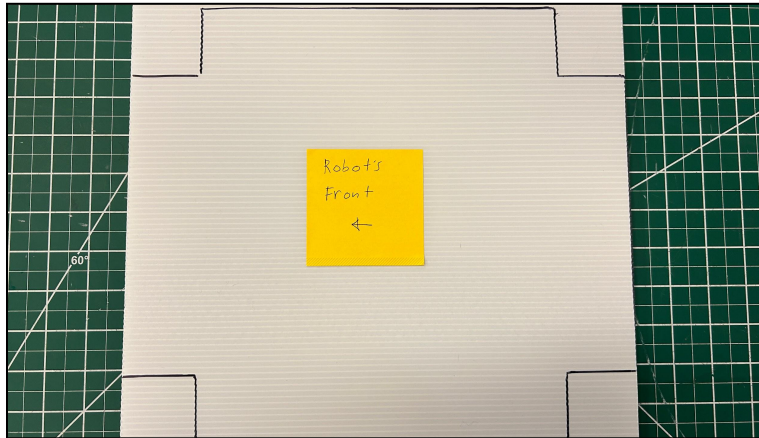

You should have a large square with a little extra plastic on top.

Note: Don't throw away any plastic pieces just yet.

3

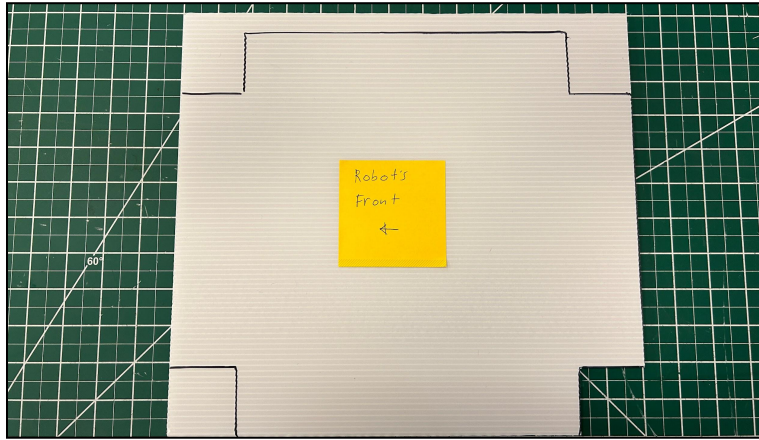

Begin removing the 50mm x 50mm square corners.

4



With all four corners removed, cut the excess plastic from the top.

5



With the shape of your belly pan now completed we'll move on to tracing outlines for the M3 Hardware.

6

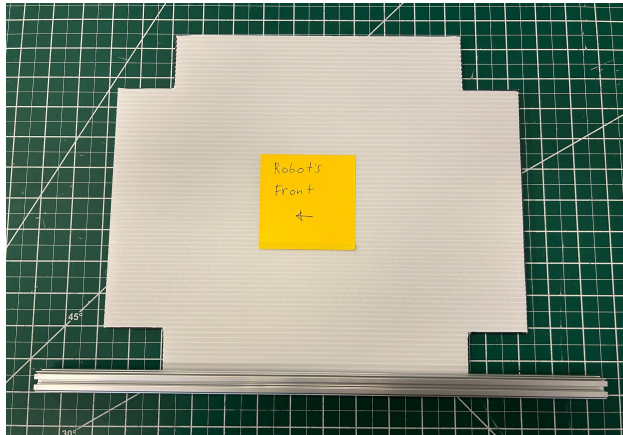

Get

- 15mm Extrusion
- Belly Pan

Place the 15mm extrusion flush along the bottom edge of the belly pan, trace line along the extrusion.

7

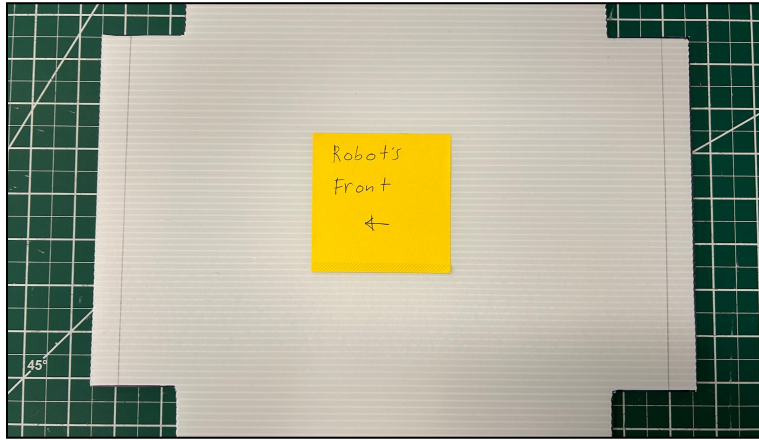

Take your extrusion and repeat the outline on each of the four edges of the Belly Pan.

8

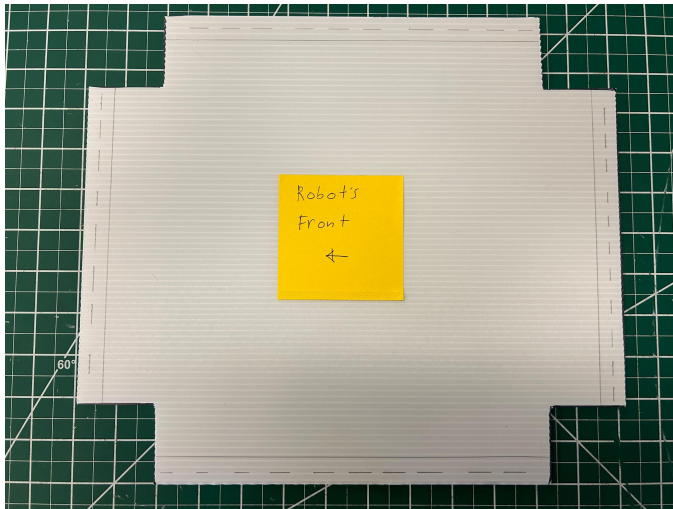

Divide the outline in half, this will serve as a guide where the M3 Hardware will need to be.

9

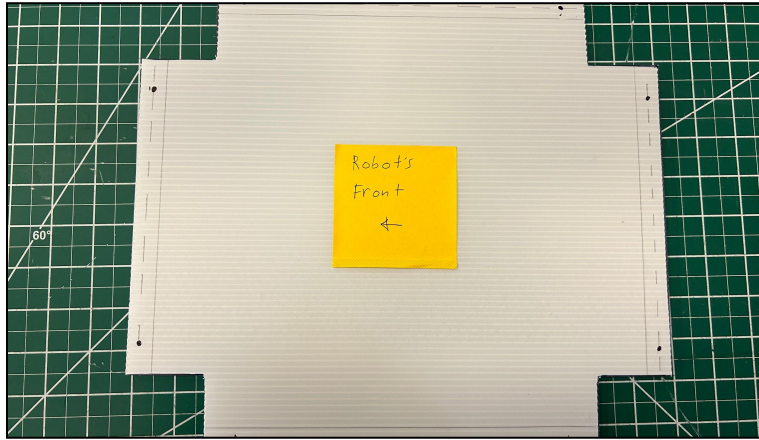

Measure and mark 15mm along the middle of the extrusion outline. Repeat this process eight times.

Next take one of the allen keys from your kit and puncture the plastic all the way through for each hole.

10



Once you have your plastic sheet cut to the appropriate dimensions and have punctured all eight holes we can move to installing the belly pan to the bottom of the starter bot.

Start by preloading all eight holes with 8mm T-Slot Screws with M3 Nyloc Nuts.

11



Be sure to load the Nyloc Nut onto the T-Slot Screw just enough so that you can push the screw up, you should have the head sticking out a little. This will allow the screw to catch the extrusion and fasten correctly and prevent the hardware from free spinning in the plastic.

12

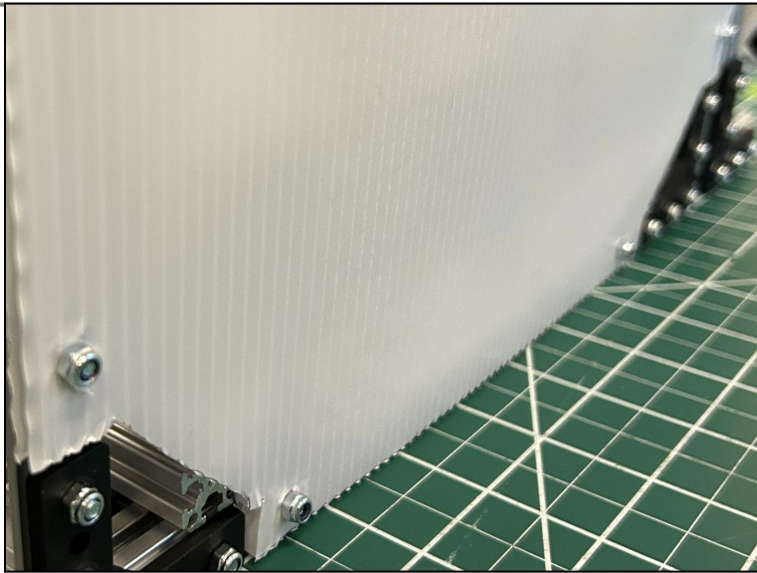

Line up the belly pan so that the T-Slot Screws go into the 15mm Extrusion cavity. Begin to fasten all eight preloaded M3 hardware points to the bottom of the robot.

Note: Make sure to not overtighten.

Plastic Intake Stabilizer

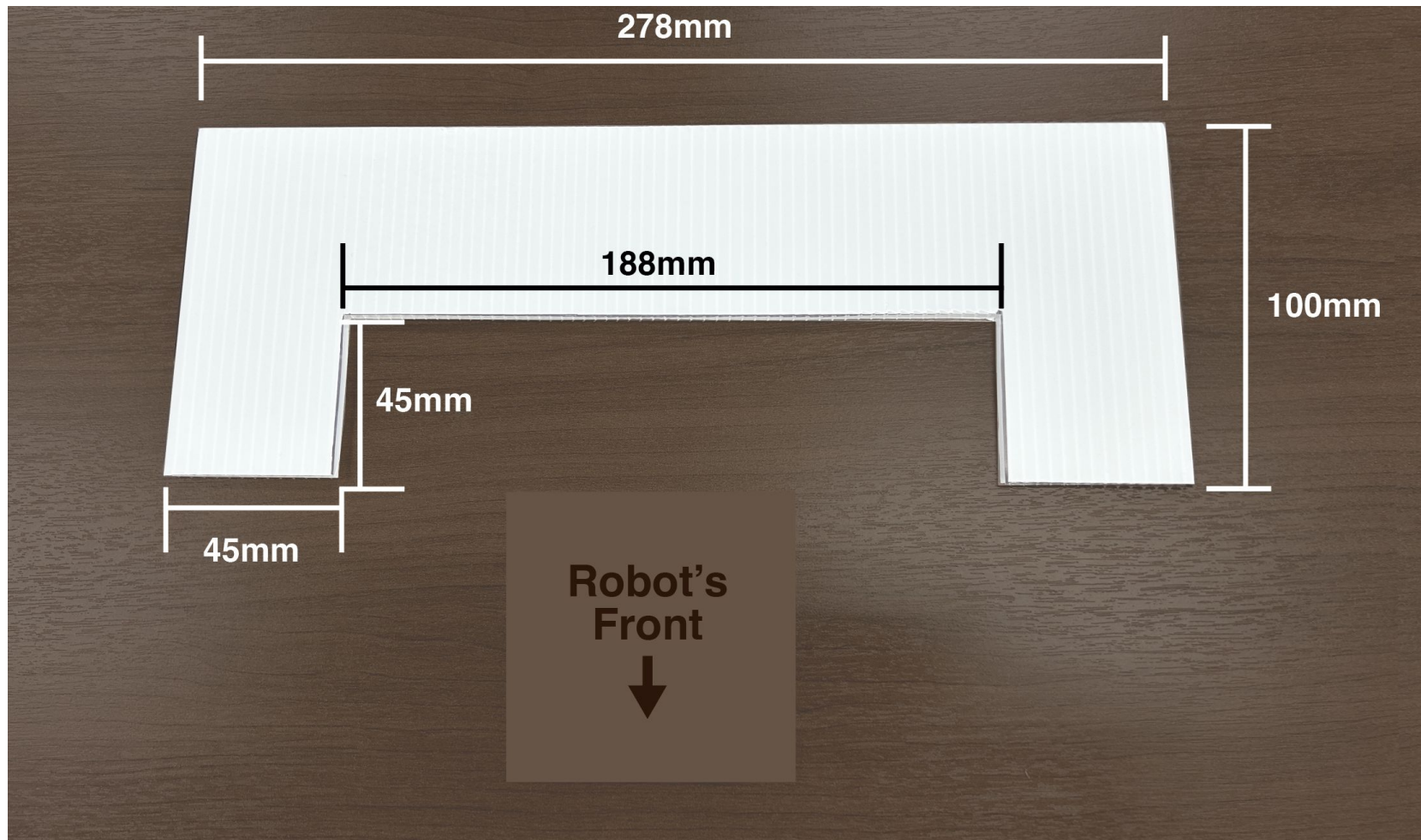

1

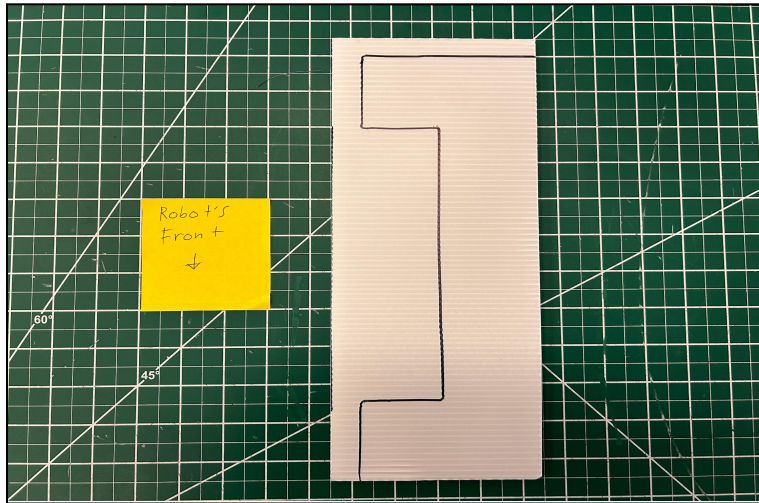

Get

- Other half of the Corrugated Plastic Sheet

Cut the excess plastic along the top horizontal 100mm line.

2

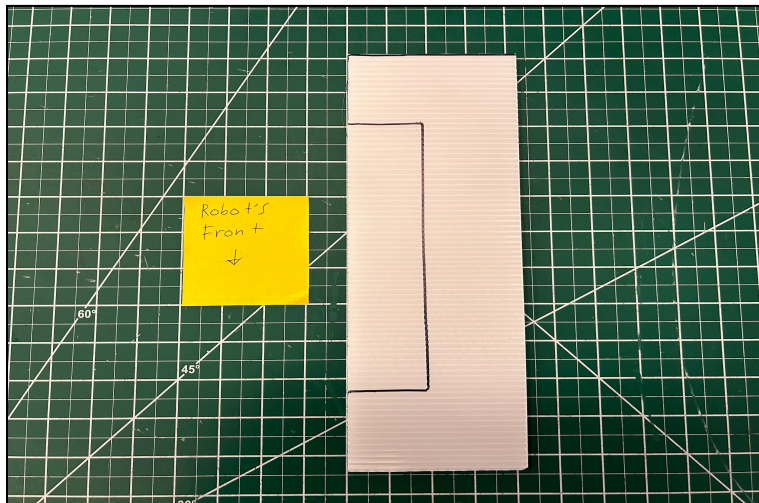

Cut the excess plastic along the vertical left 278mm line.

3

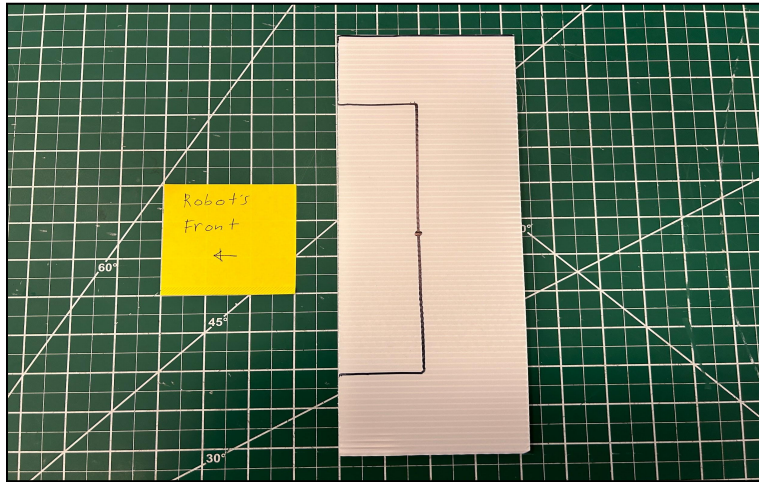

Find and mark the center point of your 188mm vertical line.

4



Center the pixel on your mark and adjust the corners to be touching your 188mm line.

Take a sharpie and trace the corner of the pixel.

5

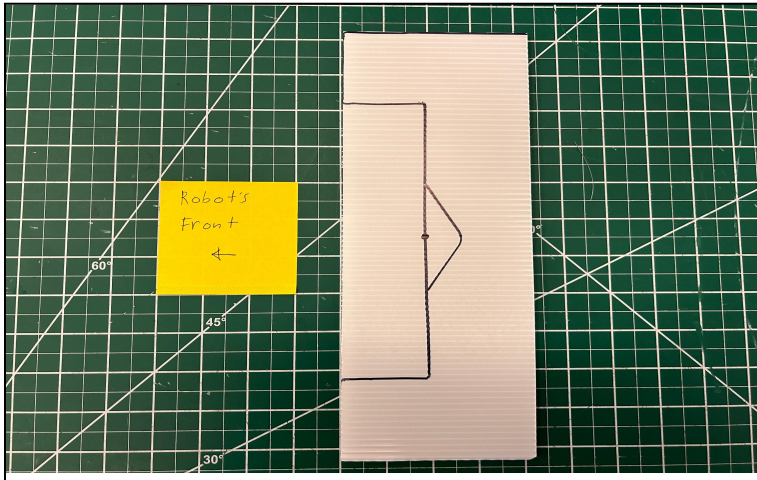

Take a sharpie and trace the corner of the pixel.

6

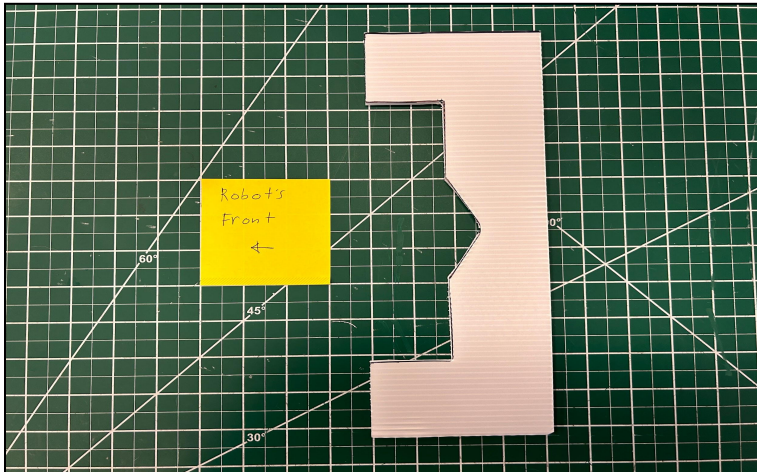

Remove the small rectangle that you have traced first.

Note: Keep this piece we'll need it later

Remove the small triangle.

7

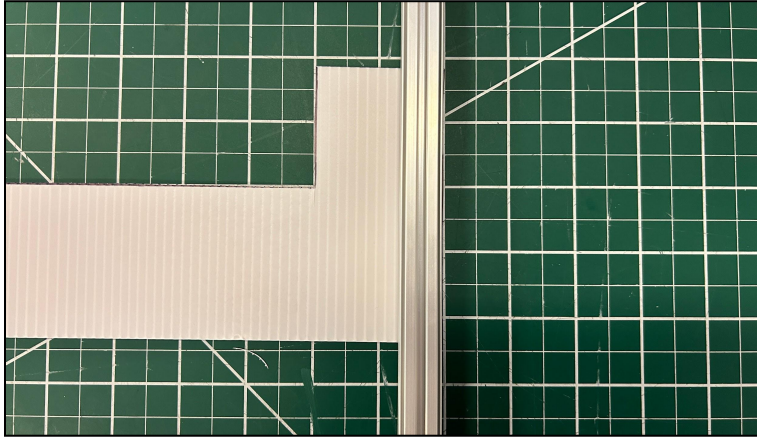

Get

- 1 x 15mm Extrusion
- Intake Stabilizer

Place the 15mm Extrusion flush along the left edge of the intake.

8

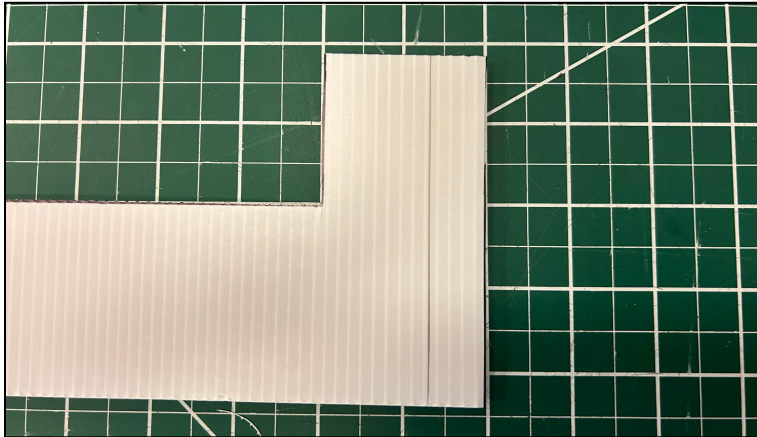

Trace a vertical line.

9

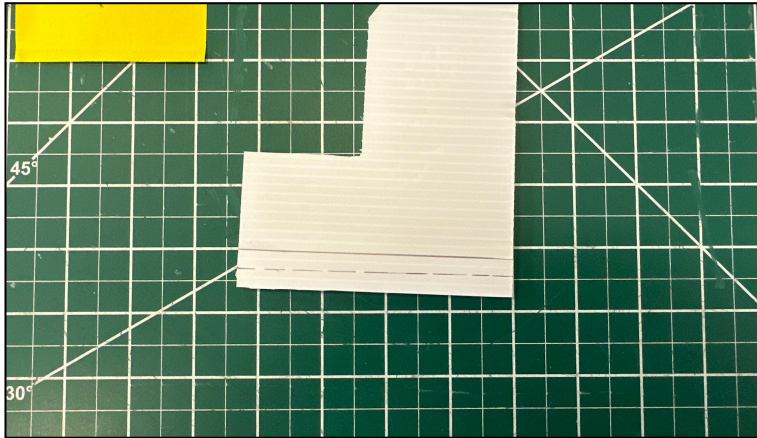

With the extrusion outline made, divide the outline in half. This will be where your M3 Hardware will sit.

10

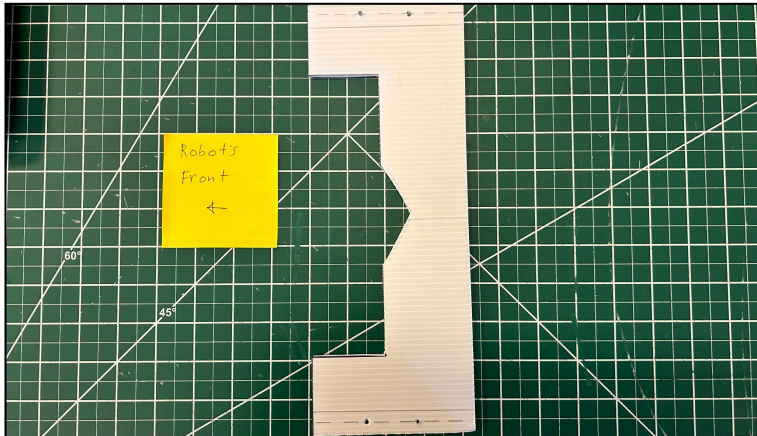

Find the center of the outlines you have made and mark two dots at 35mm apart.

11

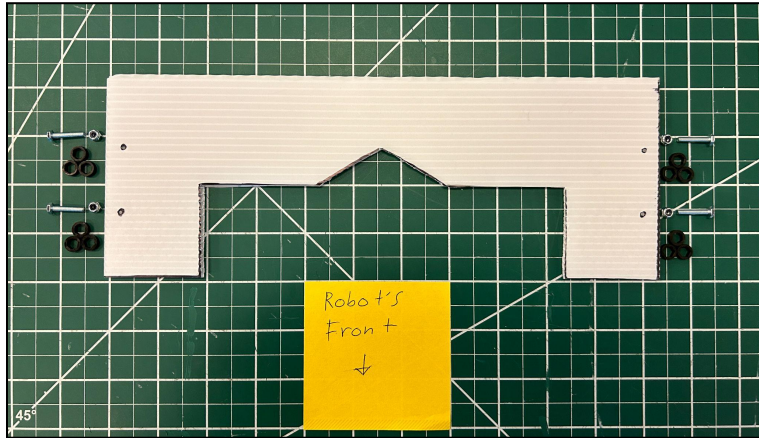

Get:

- 4 x 16mm M3 Hex Head Screws
- 12 x 3mm Spacers
- 4 x M3 Nyloc Nuts

12

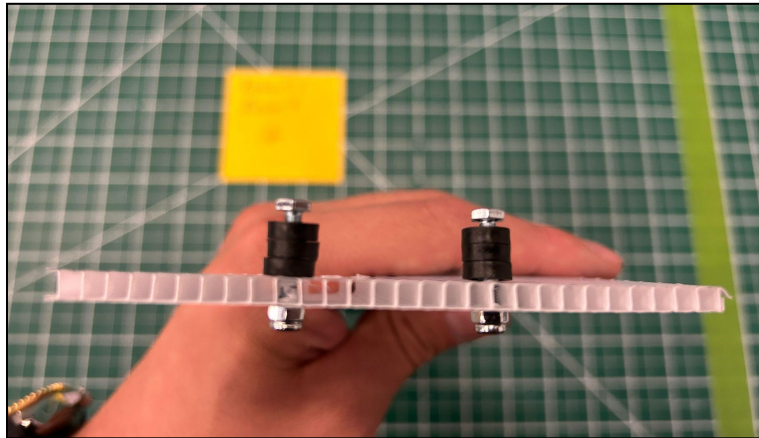

Insert the three spacers on the screw, then install the screw through the hole. Similar to the belly pan, thread the Nyloc nut on the screw but not all the way.

Note: Leave a little bit of the Hex Head sticking out so that it can slide on the C Channel cavity.

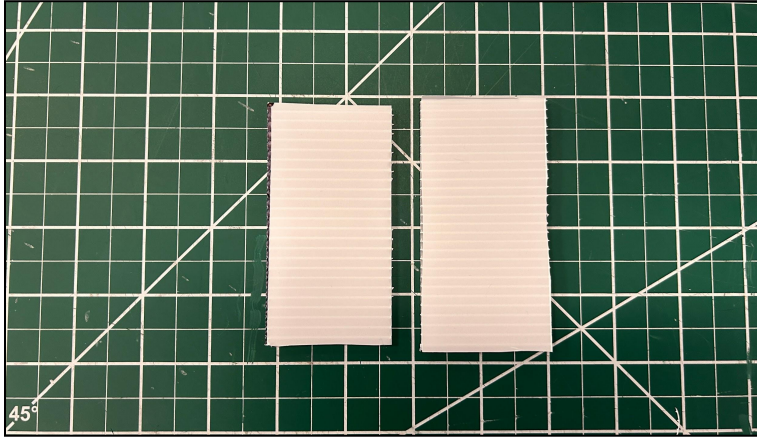

Take the small rectangle from earlier and cut it in half. Center the two pieces under your intake and trace the small triangle.

Be sure to cut the triangles and place them on top of the intake, use three zip ties to fasten everything in place.

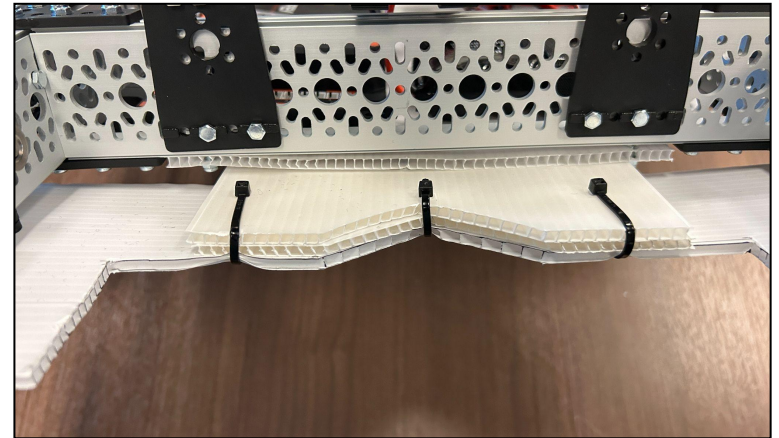
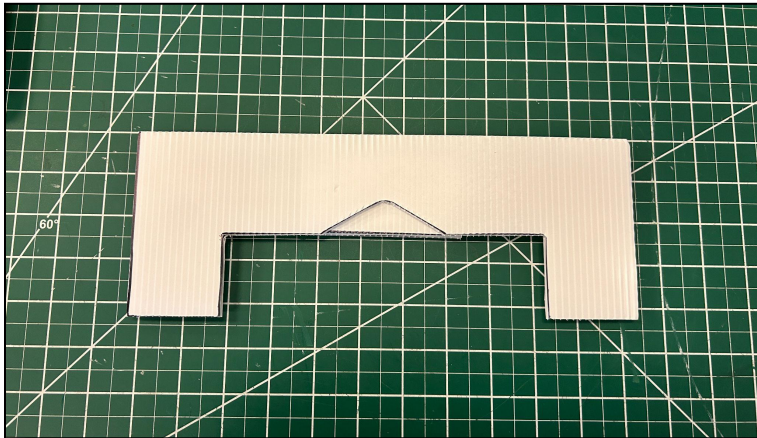

14

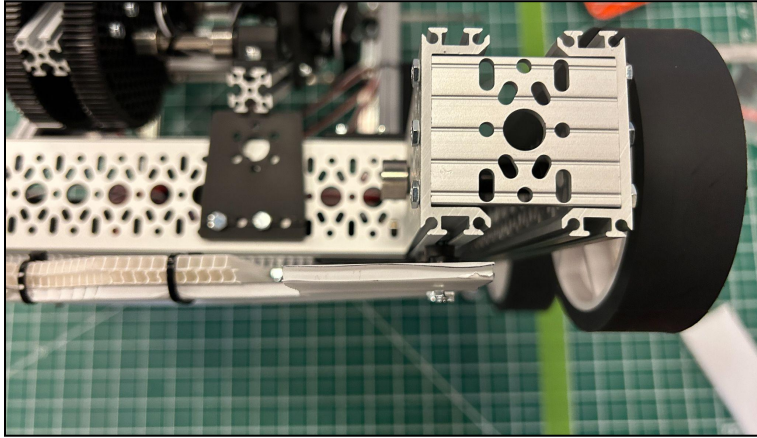

Proceed to install the Intake Stabilizer on the C Channel cavity, you should line the plastic up with the front ends of the robot so that they are flush.

15

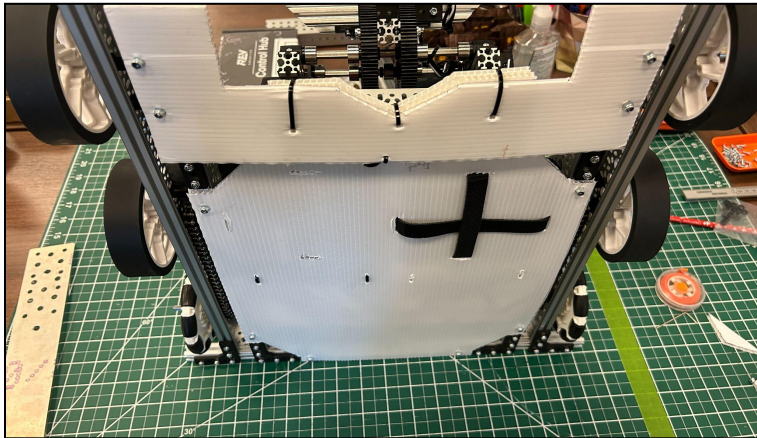

Plastic Assembly Complete

Note: Your Belly Pan will have square corners instead of angled ones that match this image and CAD files.

15

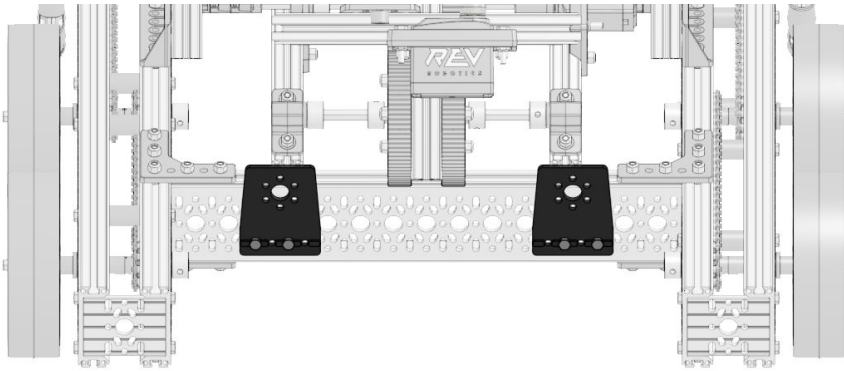

Get:

- 15mm Gearbox Motion Brackets
- 4 M3 Nyloc Nuts

Attach two Gearbox Motion Brackets where the Arm meets the Drivetrain, using Hex Cap Screws and Nyloc Nuts.

16

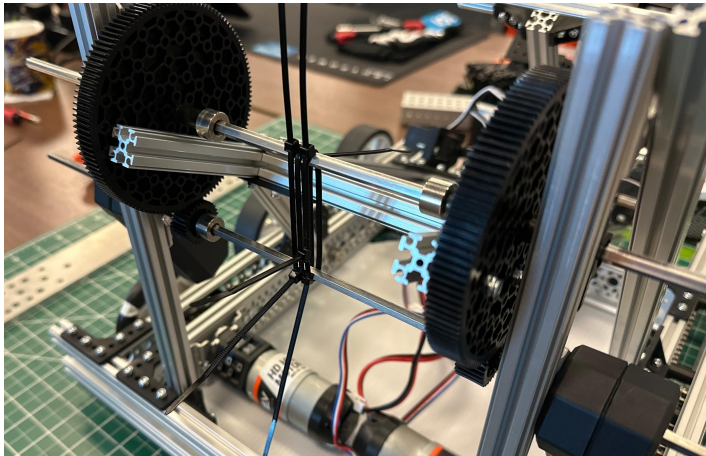

Get:

- 6 Zip Ties - 160mm

Combine 2 Zip Ties to lengthen the zip tie. Do this three times to make 3 longer Zip Ties. Using the 3 lengthened Zip Ties, zip tie the Arm shaft and the Core Hex Motor shafts. Trim the excess Zip Ties.

17



Get:

- 6 Zip Ties - 160mm
- Control Hub

Attach the Control Hub to the Belly Pan with Zip Ties.

18

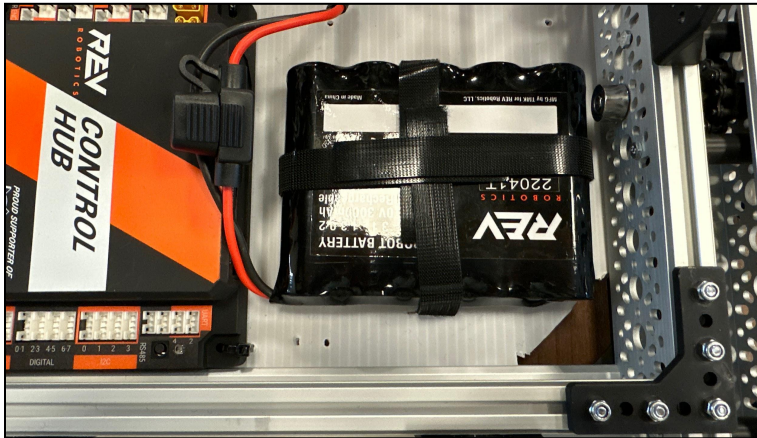

Get:

- Hook and Loop Fastener
- 12V Slim Battery

Attach the 12v Slim Battery to the Belly Pan with 2 strips of Hook and Loop Fastener.

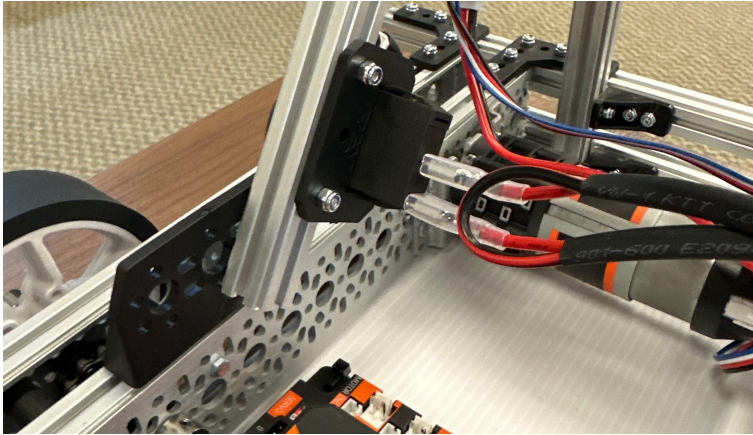
**Get:**

- Switch Cable and Bracket Set
- 2 M3 X 8mm T-Slot Screw
- 2 M3 Nyloc Nuts

Attach the Switch Bracket to the extrusion in the tower assembly using 2 T-Slot Screws and Nyloc Nuts.

Intentionally Left Blank



2023-24 REV DUO FTC Starter Bot

